

FUN with Fizz

Activity Book

Ann Jones

Primary 1



HAMILTON HOUSE
ENGLISH LANGUAGE TEACHING

FUN with FIZZ

Activity Book

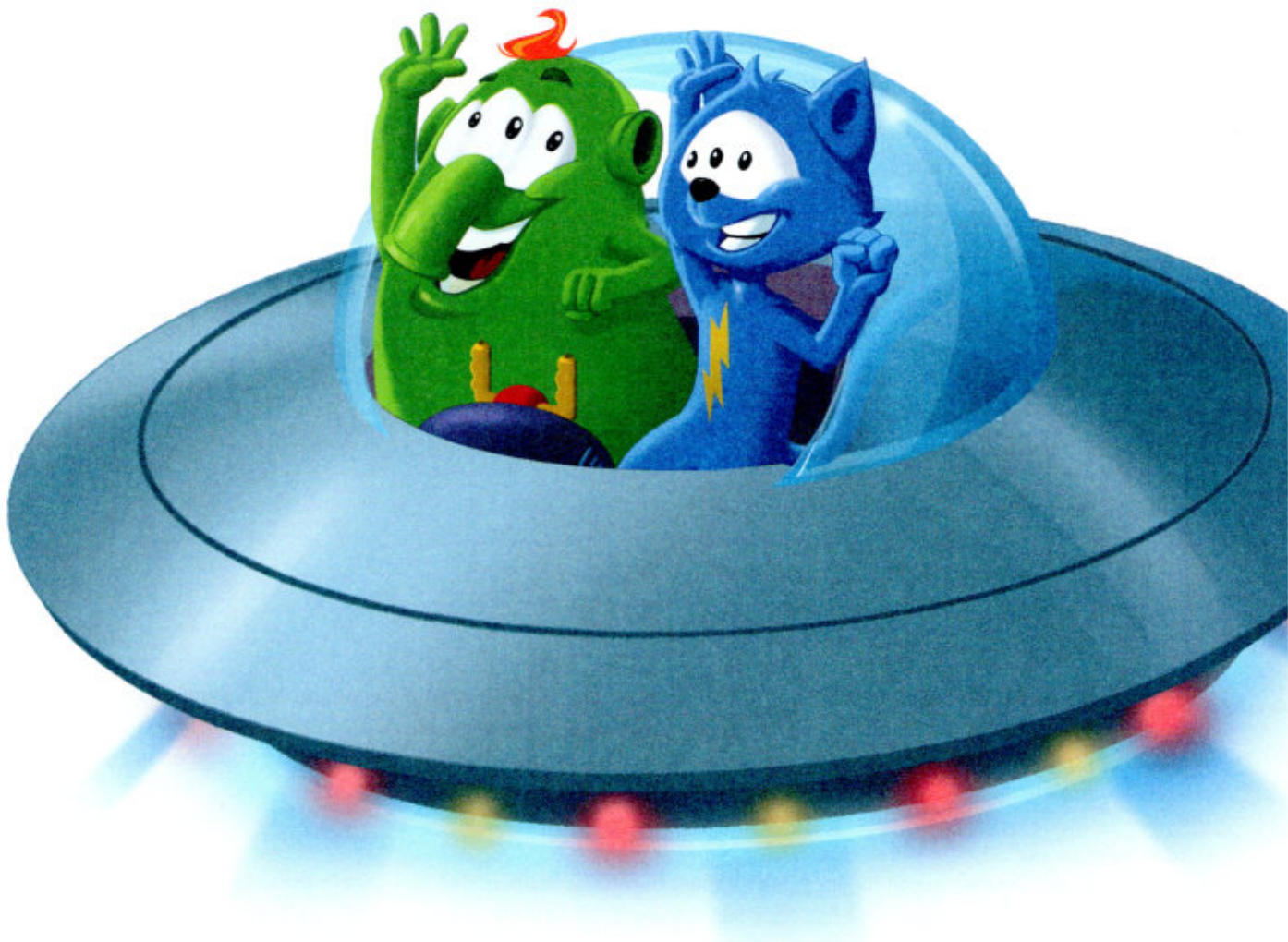

First published by Hamilton House Publishers 2015

Hamilton House Publishers Ltd
37 Bagley Wood Road
Kennington
Oxford
England

E-mail: enquiries@hamiltonhousepublishers.com
Website: www.hamiltonhousepublishers.com

Text, design, artwork and characters © Hamilton House Publishers 2015

ISBN: 978-9963-254-11-8 Fun with Fizz Primary 1 Activity Book
ISBN: 978-9963-254-12-5 Fun with Fizz Primary 1 Activity Book with key

All rights reserved. No part of this publication may be reproduced, stored in a retrieval system or transmitted in any form or by any means, electronic, mechanical, photocopying, recording or otherwise without the prior written permission of the publishers. Any person who carries out any unauthorised act in relation to this publication may be liable to criminal prosecution and civil claims for damages.

Acknowledgements

The publishers and authors would like to thank all the schools and teachers that took part in the testing and piloting of the original material. Their feedback and comments were invaluable.

Illustrations by: Panayiotis Angelatakis
Recording at GFS-PRO Studio

Unit **Page**

Unit 1

Lesson 1	4
Lesson 2	6
Lesson 3	8

Unit 2

Lesson 1	10
Lesson 2	12
Lesson 3	14

Unit 3

Lesson 1	16
Lesson 2	18
Lesson 3	20

Review 1 **22**

Unit 4

Lesson 1	24
Lesson 2	26
Lesson 3	28

Unit 5

Lesson 1	30
Lesson 2	32
Lesson 3	34

Unit 6

Lesson 1	36
Lesson 2	38
Lesson 3	40

Review 2 **42**

Unit **Page**

Unit 7

Lesson 1	44
Lesson 2	46
Lesson 3	48

Unit 8

Lesson 1	50
Lesson 2	52
Lesson 3	54

Unit 9

Lesson 1	56
Lesson 2	58
Lesson 3	60

Review 3 **62**

Unit 10

Lesson 1	64
Lesson 2	66
Lesson 3	68

Unit 11

Lesson 1	70
Lesson 2	72
Lesson 3	74

Unit 12

Lesson 1	76
Lesson 2	78
Lesson 3	80

Review 4 **82**

Extra writing pages **84**



1

Lesson 1

Hello!

A Match.

1 Matt

2 Lily

3 Fizz

4 boy

5 girl



B Write.

boy girl ~~Lily~~ Matt alien Fizz



1 L i l y



2 b _ _ _



3 g _ _ _



4 M _ _ _



5 F _ _ _



6 a _ _ _

C Write 'm or 's.

1 She 's Lily.

2 She _____ a girl.

3 He _____ Matt.

4 He _____ a boy.

5 Hello! I _____ Fizz.

6 Hello! I _____ Lily.

D Circle.

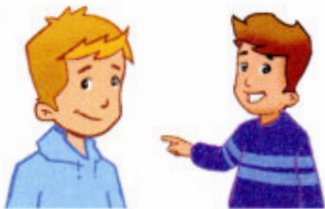

1 He's / She's a boy.



4 He's / She's Fizz.

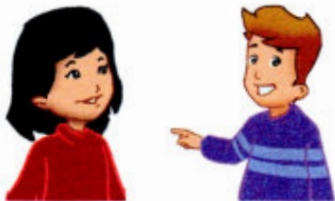

2 He's / She's a girl.



5 He's / She's Lily

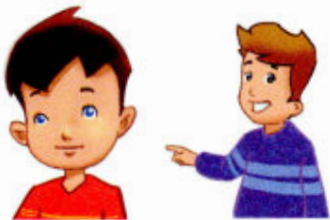

3 He's / She's Matt.



6 I'm / He's Fizz.

E Write.



1

Lesson 2

Family

A Match.

- 1 mum 2 sister 3 family 4 dad 5 baby 6 brother



B Write.

brother sister mum dad baby family



1 m u m



2 _____



3 _____



4 _____



5 _____



6 _____

C Circle.



1 **We're** / You're sisters.



3 We're / You're a girl.



2 We're / You're sisters.



4 We're / You're brothers.

D Write.

you're = you are

we're = we are

1 You are boys.

You're boys.

2 We are sisters.

3 You are a girl.

4 We are brothers.

E Write **You're** or **We're**.

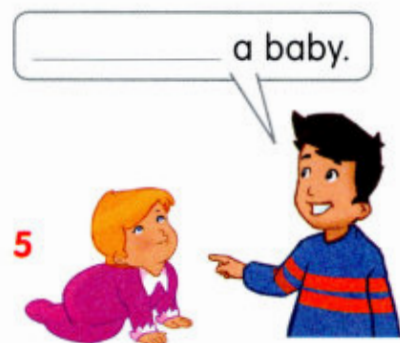
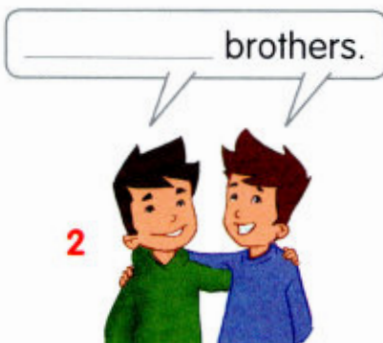

1

Lesson 3

Animals

A Match.

1 duck

2 cow

3 snake

4 bird

5 elephant



a



b



c



d



e

B Write.

cow snake duck bird



1 s n a k e



2 _____



3 _____



4 _____

C Write It's a or It's an.



1 It's a snake.



3 _____ dog.



5 _____ cat.



2 _____ elephant.



4 _____ ant.



6 _____ bird.

D Write.

it's = it is

they're = they are

1 It is a bird.

It's a bird.

4 They are snakes.

2 They are cats.

5 It is a dog.

3 It is an ant.

6 They are elephants.



E Write.

They're cows. It's a duck. They're birds.
~~They're ducks. It's a bird. It's a cow.~~



1 They're ducks. _____



4 _____



2 _____

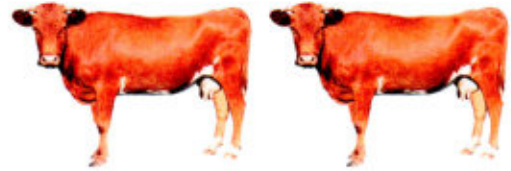

5 _____



3 _____



6 _____

F Draw and write.



1 They're snakes.

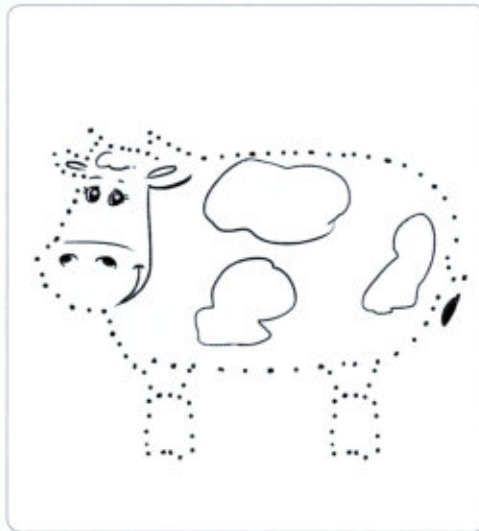

2 It's a _____.

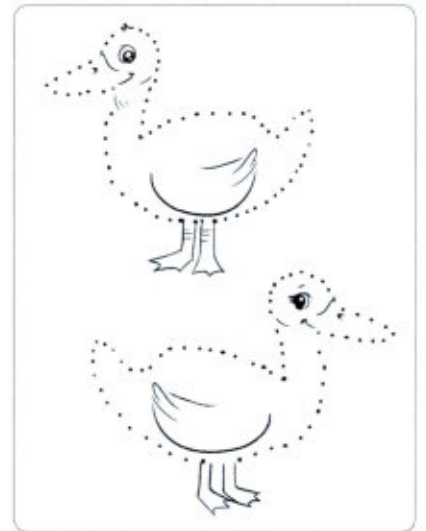

3 They're _____.

A Circle.

1 It's a hill / **field**

2 It's a river / tree.



3 It's a flower / hill.



4 It's a river / flower.



5 It's a tree / hill.

B Find and circle.

field hill river flower tree

a	b	i	l	l	b	c	d	h
h	o	v	e	r	i	v	e	r
i	b	c	f	l	o	w	e	r
l	f	i	e	l	d	o	r	g
l	i	m	t	r	e	e	b	o

C Write This is or That's.

1 That's a tree.

2 _____ a snake.



3 _____ a hill.



4 _____ a bird.



5 _____ a baby.



D Match.

- 1 This is a flower.
- 2 That is a flower.
- 3 This is a hill.
- 4 That is a hill.
- 5 This is a river.
- 6 That is a river.



E Look and write.

That's this That's Be careful

_____, Fizz!
 That's _____ a tree!



And _____ is... ?



_____ a snake!

2

Lesson 2

How are you?

A Match.

1 road

2 house

3 car

4 shop

5 town



B Write.

car shop ~~house~~ town road



1 house



2 _____



3 _____



4 _____



5 _____

C Circle.



1 These / Those are birds. 2 These / Those are cars. 3 These / Those are boys.



4 These / Those are houses.



5 These / Those are cows.

D Write.



1 These are cars.

2 _____

3 _____



4 _____

5 _____

E Draw and write.

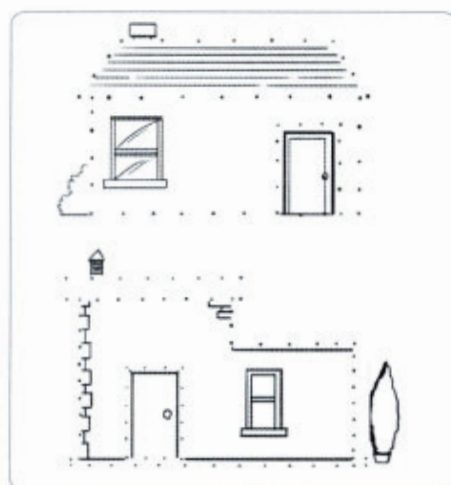
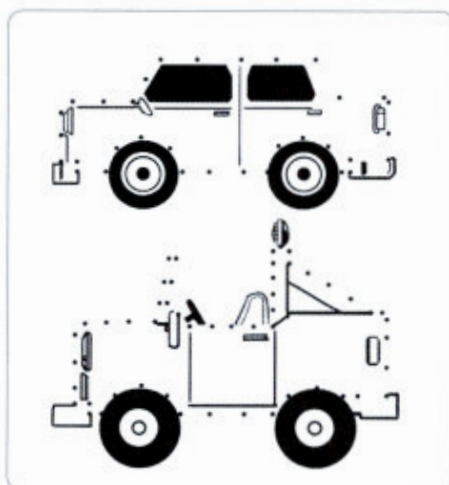

1 These are shops

2 _____

3 _____

F Write.

Hello! _____ you?



Fine, _____ you.



A Match.

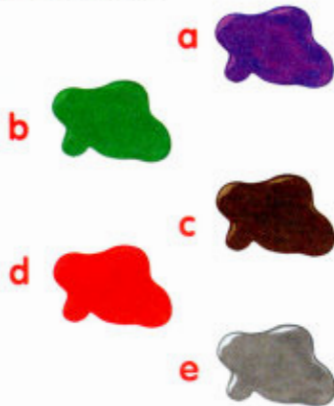

- | | | | | | |
|----------|--------------------------|---|--------------------------|-----------|--------------------------|
| 1 green | <input type="checkbox"/> | b | <input type="checkbox"/> | 6 black | <input type="checkbox"/> |
| 2 blue | <input type="checkbox"/> | | <input type="checkbox"/> | 7 brown | <input type="checkbox"/> |
| 3 pink | <input type="checkbox"/> | | <input type="checkbox"/> | 8 grey | <input type="checkbox"/> |
| 4 orange | <input type="checkbox"/> | | <input type="checkbox"/> | 9 red | <input type="checkbox"/> |
| 5 purple | <input type="checkbox"/> | | <input type="checkbox"/> | 10 yellow | <input type="checkbox"/> |

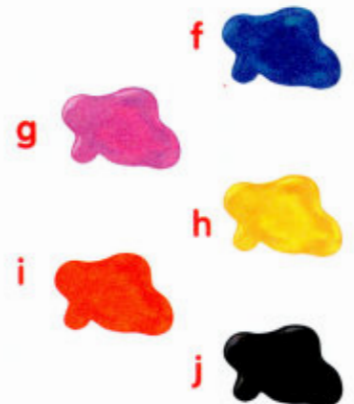

B Read and colour.

red flowers
purple snake
black and white zebra
grey elephant
orange car
blue river

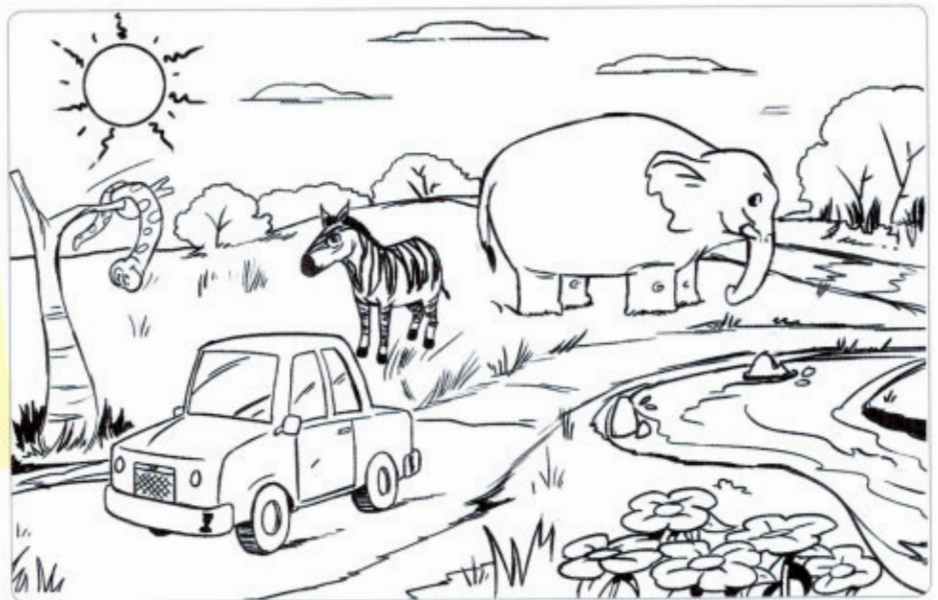

C Write.



What's this? It's a green car.

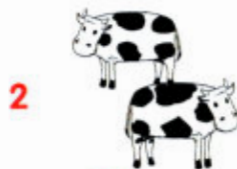

What are these? _____ and white cows.



What's this? _____ snake.



What are these? _____ flowers.



What's this? _____ bird.

D Write.



1 What's this ?
It's a fish.

2 What's _____ ?
_____ a zebra.

3 What's _____ ?
_____ a duck.



4 What are _____ ?
_____ elephants.

5 What are _____ ?
_____ kangaroos.

E Write.

What are _____ ?



_____ kangaroos.



F Read, draw and write.



This is a fish.
It's orange and black.

A Write.

thin fat tall short big small



1 tall _____



2 _____



3 _____



4 _____



5 _____



6 _____

B Circle.

1 He's **fat** / thin.4 It's **big** / small.2 She's **short** / tall.5 He's **short** / tall.3 They're **big** / small.6 They're **fat** / thin.

C Read and match.

1 We aren't tall. We're short.

c

2 I'm not fat. I'm thin.

3 We aren't big. We're small.

4 I'm not small. I'm big.



a

b



c



d



D Write.

- 1 You are not big.
You aren't big. _____
- 2 They are not birds.

- 3 I am not tall.

- 4 He is not small.

- 5 We are not aliens.

E Write 'm not, isn't or aren't.

- 1 We aren't brothers.
- 2 They _____ fat.
- 3 I _____ short.
- 4 You _____ a small boy.
- 5 He _____ tall.
- 6 It _____ a snake.
- 7 She _____ a baby.
- 8 You _____ sisters.

F Write.

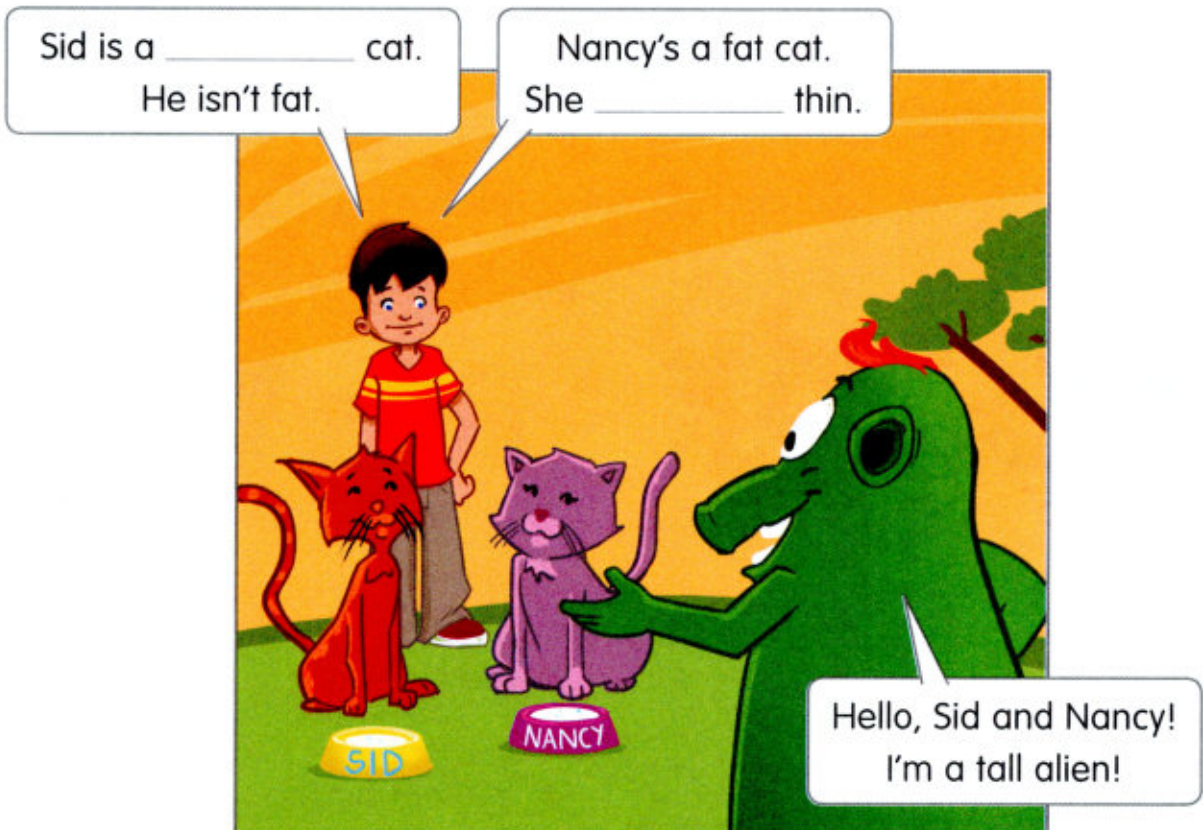

How old are you?

A Match.

11	twelve	16
12	eleven	17
13	thirteen	18
14	fifteen	19
15	fourteen	20
	sixteen	
	nineteen	
	seventeen	
	eighteen	
	twenty	

B Count and write.

- 1 eleven aliens
- 2 _____ ants
- 3 _____ birds
- 4 _____ flowers
- 5 _____ cats

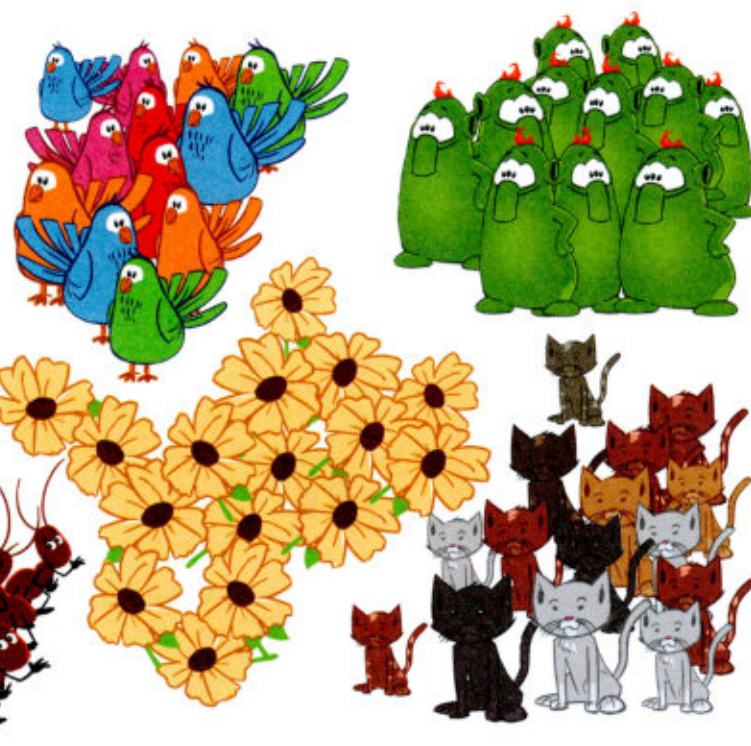

C Write.

- | | |
|---|--------------------|
| 1 You are tall.
<u>Are you tall?</u> | 3 We are thin. |
| 2 I am short. | 4 You are sisters. |

D Write.

Are you an alien? Yes, I am.

1 

Are we brown? No, _____.

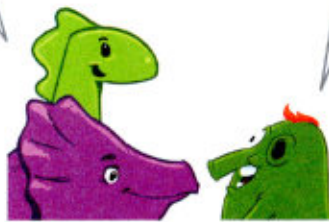
4 

Are you sixteen? No, _____.

2 

Are you ducks? Yes, _____.

5 

Am I green? Yes, _____.

3 

Am I tall? No, _____.

6 

E Write.

_____ ten,
Matt?

No, _____.
I'm eleven. How old
_____, Fizz?

Er, I'm eleven.



F Read and write.

Hello, I'm Alex.
I'm eight.
How old are you?

3

Lesson 3

Party

A Write.



1 c o s t u m e



2 p _ _ _ y



3 b _ _ _



4 c _ w _ _ y



5 _ _ _ o _ a _ r



6 q _ _ _ _

B Write.

cowboy books queen dinosaur costume party



1 It's a party .



4 It's a .



2 They're .



5 He's a .



3 She's a .



6 It's a .

C Write.

- 1 It is a party.
Is it a party _____ ?
- 2 It is a dinosaur.
_____ ?
- 3 He is a cowboy.
_____ ?
- 4 She is a queen.
_____ ?
- 5 They are books.
_____ ?

D Write are, aren't, is or isn't.

- 1 Is _____ it a dinosaur?
No, it isn't _____ .
- 2 _____ Fizz an alien?
Yes, _____ .
- 3 _____ she ten?
No, _____ .
- 4 _____ they presents?
Yes, _____ .
- 5 _____ they small?
No, _____ .

E Write.

_____ it a party, Lily?

Yes, _____ .



The illustration shows a green alien with a red tuft on its head and a girl with orange hair looking into a window. Inside the window, a group of children are having a party with balloons and streamers.



Review 1

Units 1-3

A Write.

girl sister ~~dad~~ shops mum bird field boy trees
town roads house cars ~~queen~~ cowboy brother

He	She	It	They
dad	mum	town	cars
_____	_____	_____	_____
_____	_____	_____	_____
_____	_____	_____	_____

B Circle.

I'm / She's a queen.

1



You're / We're girls.

2



He's / She's a cowboy.

3



They're / We're small.

4



You're / I'm a family.

5



He's / She's a boy.

6



C Write.

1 Are you sisters?

No, we aren't.

2 _____ he short?

No, he _____.

3 _____ I fat?

No, you _____.

4 _____ they ducks?

Yes, they _____.

D Write.

1 She isn't fat. She's thin.

2 It _____ purple. It's blue.

3 They _____ birds. They're snakes.

4 He _____ big. He's small.

5 We _____ tall. We're short.

6 You _____ ten. You're eleven.

E Write **this, that, these** or **those**.



What's this ?
It's a costume.



What are _____ ?
They're houses.



What are _____ ?
They're shops.



What's _____ ?
It's a river.



What's _____ ?
It's a hill.



What are _____ ?
They're flowers.

F Circle.

13

18

11

1 three / thirteen

2 eighteen / nineteen

3 eleven / seven

12

14

4 twenty / twelve

5 fourteen / four

G Read and colour.

The hill is brown. The river is blue. The field is green and the tree is green. The snake is purple and grey. The cow is black and white. The bird isn't brown. It's orange. The flowers aren't purple. They're pink.

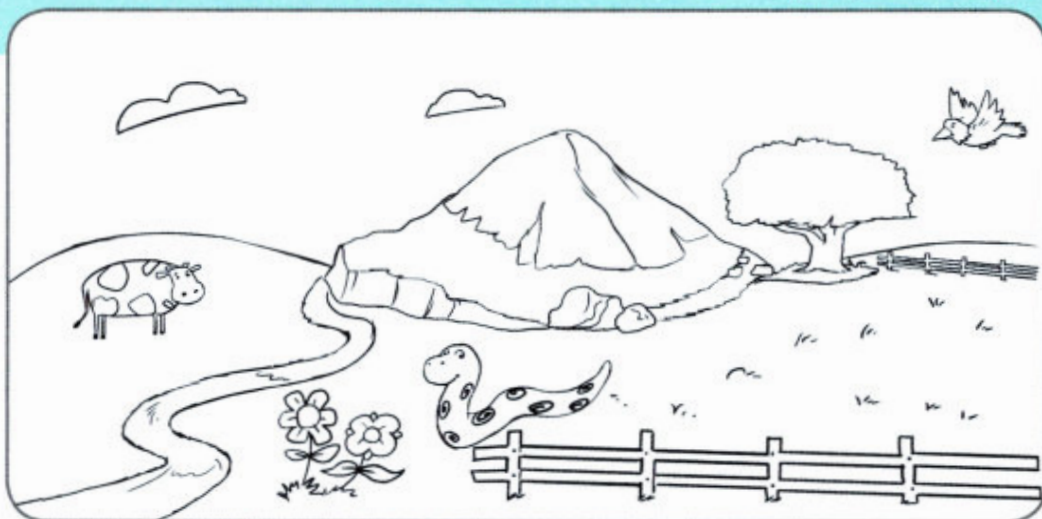

A Match.

- 1 bookcase 2 classroom 3 whiteboard 4 school bag 5 desk



B Write.



- 1 There's a whiteboard in the classroom.
- 2 There are two _____ in the classroom.
- 3 There's a _____ in the classroom.
- 4 There are three _____ in the classroom.

C Write.

- 1 There's a desk in the classroom.
There is a desk in the classroom.
- 2 There's a book in the schoolbag.
 _____ a book in the school bag.
- 3 There's a duck in the river.
 _____ a duck in the river.
- 4 There's a boy in the classroom.
 _____ a boy in the classroom.

D Circle.

- 1 There's / **There are** fifteen books in the bookcase.
- 2 There's / **There are** a girl in the classroom.
- 3 There's / **There are** ten desks and ten school bags.
- 4 There's / **There are** two birds in that tree.
- 5 There's / **There are** a dog in the house.

E Write **There's** or **There are**.

- 1 There's a cow in the field.
- 2 _____ eighteen boys in the river.
- 3 _____ a small baby in the house.
- 4 _____ a big road in this town.
- 5 _____ two books in the school bag.

F Write.

Look, Fizz! This is a classroom.

_____ sixteen desks in this classroom.

_____ a whiteboard in this classroom. _____ a big bookcase, too.

_____ a book in that school bag.

A Circle.

1

ruler / rubber

2



pen / pencil

3



computer / ruler

4



ruler / pen

5



rubber / pencil

B Write.

1 computer

2 _____

3 _____

4 _____

5 _____

C Write *Is there, Are there.*

- 1 Is there _____ a pencil in this school bag?
- 2 _____ a whiteboard in that classroom?
- 3 _____ books in the bookcase?
- 4 _____ a ruler in that school bag?
- 5 _____ ten desks in the classroom?

D Write *There isn't or There aren't.*

- 1 There's a pen in this classroom. There isn't a pen in this classroom.
- 2 There are ten computers in this house. _____ ten computers in this house.
- 3 There's an alien in this car. _____ an alien in this car.
- 4 There are two flowers in this shop. _____ two flowers in this shop.
- 5 There's a ruler in this school bag. _____ a ruler in this school bag.

E Write.

- 1 Is there a duck in that river?
No, there isn't.
- 2 _____ two birds in that tree?
Yes, _____.
- 3 _____ three zebras in this house?
No, _____.
- 4 _____ a pencil in that school bag?
Yes, _____.
- 5 _____ a computer in this classroom?
No, _____.

F Write.



G Read and write.

My school bag is blue. There are two books and a ruler in my school bag. There is a red pencil and a black pen.

A Write.

moon sky star sun sea



1 moon

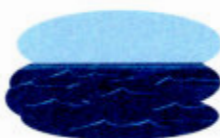

2 _____



3 _____



4 _____



5 _____

B Match.

- The sky is blue.
- The sea is blue.
- The moon is white.
- The sun is yellow.
- The stars are white.

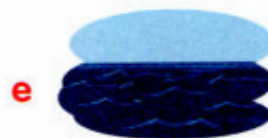
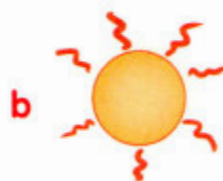

C Circle.

- There is a fish in the / a / an sea.
- Look! There's **the** / a / an snake. The snake is orange.
- Look at **the** / a / an moon.
- The** / A / An sky is blue.
- Look at **the** / a / an sun! It's red!
- That is **the** / a / an ant. **The** / A / An ant is brown.

D Write **the**, **a** or **an**.



1 This is a bird. The bird is yellow.



2 Look! There's _____ orange snake. _____ snake is small.



3 'What's that?' 'It's _____ flower. _____ flower is red.'



4 This is _____ elephant. _____ elephant is grey.



5 Look! There's _____ dog in _____ sea.

E Write **the**, **a** or **an**.

Look at _____ sun!

Look at _____ sea!

_____ sea is very blue,

_____ sky is blue too!

1 2 3 4 5, _____ sky is blue too!

Look, there's _____ fish!

_____ fish is in the sea.

Look, there's _____ ant!

_____ ant is in a tree!

1 2 3 4 5, _____ ant is in a tree!



A Write.

aunt grandma uncle grandpa mum dad cousins

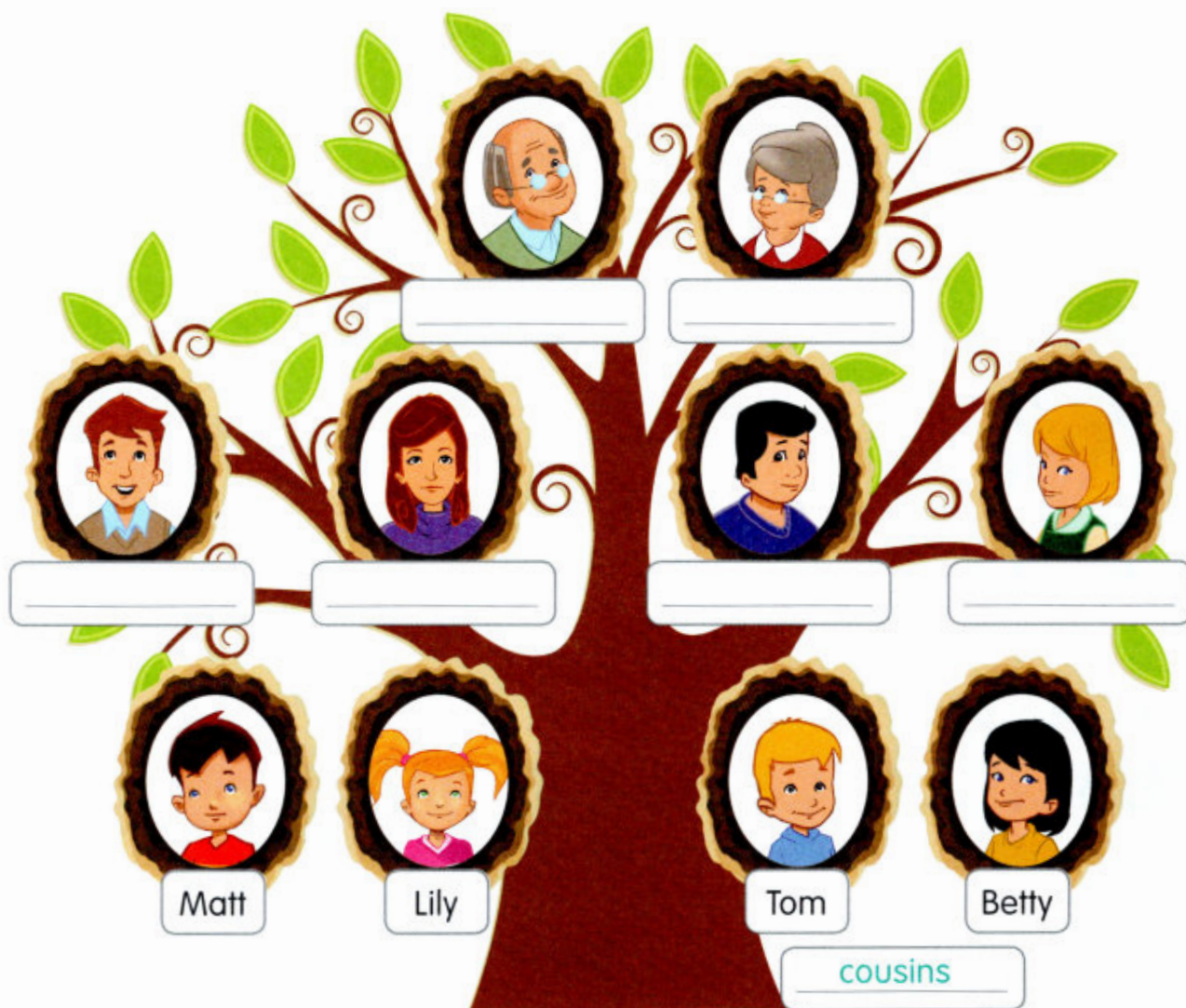

B Write.

grandma grandpa uncle
~~aunt~~ cousins

- 1 She's an aunt .
- 2 He's an _____.
- 3 They're _____.
- 4 She's a _____.
- 5 He's a _____.

C Write.

- 1 I've got an uncle.
I have got an uncle.
- 2 They've got two cousins.
They _____ two cousins.
- 3 You've got three brothers.
You _____ three brothers.
- 4 We've got a big family.
We _____ a big family.

D Write I've got, You've got, We've got or They've got.

They've got a grandpa.



_____ an aunt, Matt.

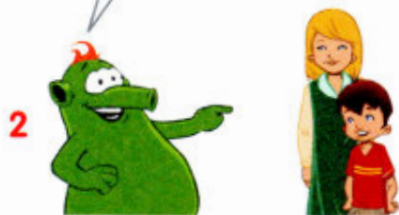

_____ presents,
Mike and Ben.



_____ an orange cat.



_____ two cousins.



E Write and match.



1 I _____ 've got _____ a book.



2 They _____ pencils.



3 We _____ flowers.



4 You _____ two birds.

F Read, draw and write.



Hello, I'm Fred.
This is my family. I've got a
mum and a brother. I've got
a grandpa and two grandmas.
I've got an aunt, an uncle
and a cousin.

A Write.



1 t o y



2 t _ _ _ y



3 _ a _ _



4 _ _ _ l



5 _ k _ _ e _ _ a _ d

B Write.



C Write.

a ①



b ②



c ③



d ④



- 1 It's got a flower.
- 2 He's got a _____.
- 3 Tom's got two _____.
- 4 Lily's got a _____.
- 5 She's got a _____.

e ⑤



D Write.

- 1 He has got a toy.
_____ **He's got** _____ a toy.
- 2 The girl has got a car.
_____ a car.
- 3 It has got a ball.
_____ a ball.
- 4 Lily has got a sister.
_____ a sister.
- 5 Matt has got two cats.
_____ two cats.



E Write.

This is Polly. Polly (1) **'s got** _____ a brother. He (2) _____ a dog.
It (3) _____ a red ball. Polly (4) _____ a cat.
It (5) _____ a toy. Polly (6) _____ two uncles and two aunts.
She (7) _____ six cousins. She (8) _____ two grandmas
and two grandpas. Polly (9) _____ a big family.

F Write.

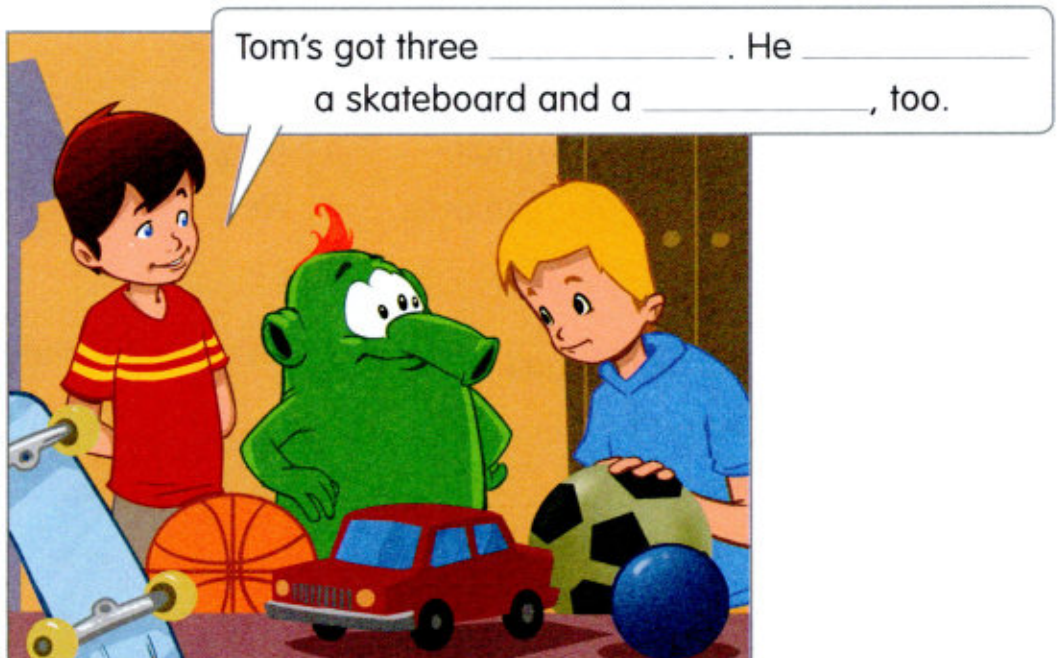

A Match.

- 1 brown hair 2 mouth 3 eye 4 ear 5 nose 6 blonde hair



B Write.

- 1  She hasn't got a blue
nose .
- 2  It hasn't got small
.

- 3  I haven't got brown
.

- 4  They haven't got blonde
.
- 5  It hasn't got a small
.

C Write haven't or hasn't.

- 1 You haven't got big ears. 4 It _____ got a big nose.
- 2 I _____ got brown hair. 5 They _____ got a cat.
- 3 She _____ got green eyes. 6 We _____ got a big house.

D Write.

- 1 They have not got blonde hair.
- 2 I have not got big ears.
- 3 She has not got a car.
- 4 It has not got a big mouth.
- 5 We have not got a computer.

They haven't got blonde hair.



E Write.

- 1 The boys have got green eyes. They haven't got blue eyes.
- 2 I've got red hair. _____ blonde hair.
- 3 The girl's got a red school bag. _____ a grey bag.
- 4 Mike's got a cat. _____ a dog.
- 5 The elephant's got big ears. _____ small ears.
- 6 We've got three cousins. _____ four cousins.

F Write.

This is Chico, the cat. It has got green
_____ and a very small nose.
It _____ a big mouth but it has
got very big _____!



G Read and write.

Hello, I'm Penny. I've got blonde hair and blue eyes. My mum's got blonde hair and my dad's got brown hair. My brother's got blonde hair and brown eyes.

A Match.

1 body

2 head

3 leg

4 arm

5 tail



B Write

1 Has Buzz got two heads ?

No, he hasn't.

2 Has Buzz got a blue and yellow _____ ?

Yes, he has.

3 Has Buzz got a long _____ ?

Yes, he has.

4 Has Buzz got three _____ ?

No, he hasn't.

5 Has Buzz got two _____ ?

Yes, he has.



C Write.

- | | | |
|----------------------------|---------------------|---------------|
| 1 You have got two arms. | <u>Have you got</u> | two arms? |
| 2 I have got green eyes. | _____ | green eyes? |
| 3 He has got a small head. | _____ | a small head? |
| 4 She has got blonde hair. | _____ | blonde hair? |
| 5 They have got a ball. | _____ | a ball? |
| 6 It has got a tail. | _____ | a tail? |

D Match.

- 1 Have I got a friend?
 - 2 Has it got a big mouth?
 - 3 Have they got red hair?
 - 4 Have we got a computer?
 - 5 Has he got big ears?
 - 6 Has she got a cat?
- a Yes, it has.
 - b Yes, you have.
 - c No, he hasn't.
 - d Yes, they have.
 - e Yes, she has.
 - f No, you haven't.

E Write.

1  Has it got
a big nose?

No, it hasn't.

2  _____ it _____
a long tail?

Yes, _____.

3  _____ Lily _____
blonde hair?
Yes, _____.

3  _____ Matt _____
blonde hair?

No, _____.

4  _____ you _____
two legs?

Yes, _____.

5  _____ they _____
flowers?
No, _____.

F Write.

Has Buzz _____
a sister?

No, he _____. He's got
two brothers, Bip and Bop.

_____ they _____ tails?

Yes, they _____.
They've got long tails!

6

Lesson 2

It's my bed!

A Write.

bed bedroom blanket table chair



1 b e d r o o m



2 _ _ _ l _ _



3 _ e _



4 c _ _ i _ _



5 _ l _ _ k _ _

B Write.

1 This is our bedroom.

2 This is my _____.



3 That's their _____.

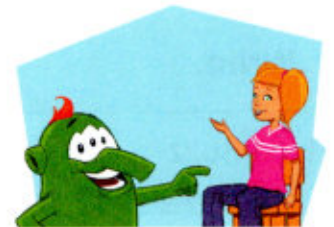

4 That's his _____.

5 That's her _____.

C Circle.

- I've got a bird. **My** / **Its** bird is yellow.
- He's got a ball. **Her** / **His** ball is blue.
- We've got a snake in **our** / **your** bedroom.
- They've got four computers in **their** / **her** classroom.
- Has she got a cat in **its** / **her** house?
- Have you got a table in **their** / **your** bedroom?
- I've got a school bag. **My** / **Our** school bag is brown.

D Match.

- | | |
|--------|---------|
| 1 I | a your |
| 2 you | b his |
| 3 he | c my |
| 4 she | d its |
| 5 it | e her |
| 6 we | f their |
| 7 they | g our |

E Write.

My ~~Your~~ Our His Her Their Its Your

- 1 You've got a table. Your table is small.
- 2 We've got a car. _____ car is grey.
- 3 He's got a blanket. _____ blanket is purple.
- 4 It's got a toy. _____ toy is big.
- 5 I've got a friend. _____ friend is tall.
- 6 You've got a family. _____ family is big.
- 7 They've got a cat. _____ cat is white.
- 8 She's got a bird. _____ bird is small.

F Write.

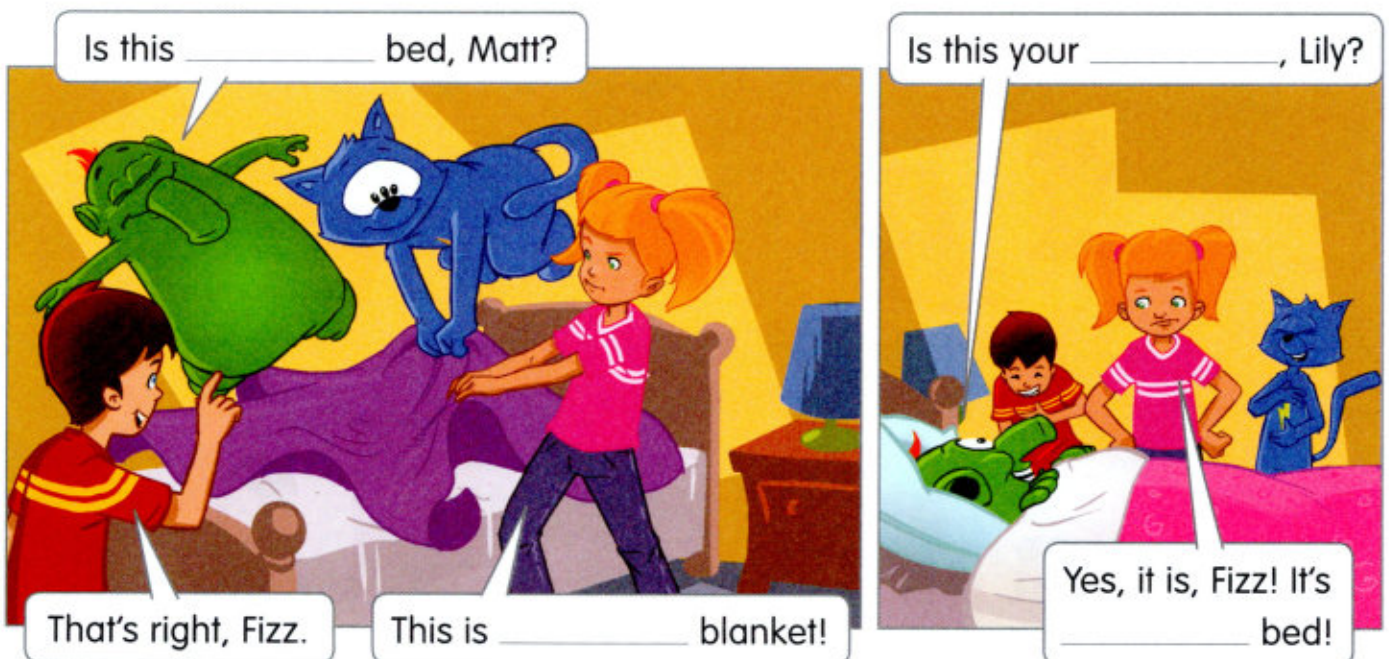

Stop, Buzz!

A Circle.



- 1 on / under 2 under / on 3 sofa / cupboard 4 TV / sofa 5 cupboard / TV

B Write.



- 1 Dad's book is on the chair. 2 The boy's duck is on the _____ . 3 Matt's ball is on the _____ .



- 4 Betty's doll is _____ the table. 5 My teddy is in the _____ .

C Write.

This is Mum's cupboard This is Matt's blanket.
This is Dad's sofa. These are Lily's chairs.



- 1 This is Matt's blanket. 3 _____



- 2 _____ 4 _____

D Write.



1 This is Lily's car.
It's her car.



2 This is _____ ball.
It's his ball.



3 This is the _____ present.
It's his present.



4 These are _____ skateboards.
They're his skateboards.



5 This is _____ book.
It's his book.

E Write.

1 Mum / chair
It's Mum's chair.

2 Matt / pencil
It's _____.

3 the cat / toy
It's _____.

4 Lily / pens
They're _____.

5 the girl / blanket
It's _____.

F Write.

He's _____ the TV. He's
_____ Tom's skateboard!





Review 2

Units 4-6

A Write.

pencil moon mouth ~~tail~~ blanket bedroom



1 t a i l



2 _____



3 _____



4 _____



5 _____



6 _____

B Write.



Fizz and Buzz are friends. They are aliens, too!

Fizz is green. He's got a short, fat (1) body and a big (2) _____. He's got big (3) _____, too. He's got two arms and two (4) _____. He's got red (5) _____, but he hasn't got a tail.

Buzz is blue and yellow. He isn't fat. He's got two (6) _____ and two legs and a long (7) _____.

Fizz and Buzz haven't got two (8) _____ - they've got three!

C Write.

- I haven't got _____ a pencil. I've got a pen.
- _____ you _____ a computer? No, I _____.
- My aunt _____ a cat. She's got a bird.
- _____ Grandpa _____ white hair? Yes, he _____.
- Our uncle _____ a bookcase. It's a big bookcase.
- They _____ three cousins. Their cousins are tall.

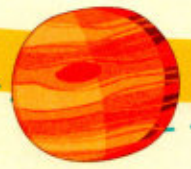

D Write a, an or the.

- 1 Look! There's a snake. The snake is in the classroom.
- 2 There's _____ ball in the bedroom. _____ ball on the bed.
- 3 Look at _____ sun. It's orange!
- 4 There's _____ skateboard under his bed. _____ skateboard's blue.
- 5 There's _____ big bird in _____ sky.

E Write.

- 1 Is there _____ a toy in the cupboard? Yes there is _____ .
There is _____ a toy in the cupboard.
- 2 _____ books in the bookcase? No, _____ .
_____ books in the bookcase.
- 3 _____ a doll on the girl's bed? No, _____ .
_____ a doll on the girl's bed.
- 4 _____ three bedrooms in your house? Yes, _____ .
_____ three bedrooms in my house.

F Write.



- 1 These are Matt's chairs.
They're his chairs.



- 2 These are _____ rulers.
They're _____ rulers.



- 2 These are the _____ toys.
They're _____ toys.



- 4 This is _____ sofa.
It's _____ sofa.



- 5 This is the _____ desk.
It's _____ desk.

A Match.

- 1 pizza 2 eat 3 spaghetti 4 omelette 5 chips 6 kitchen 7 cook



B Write.

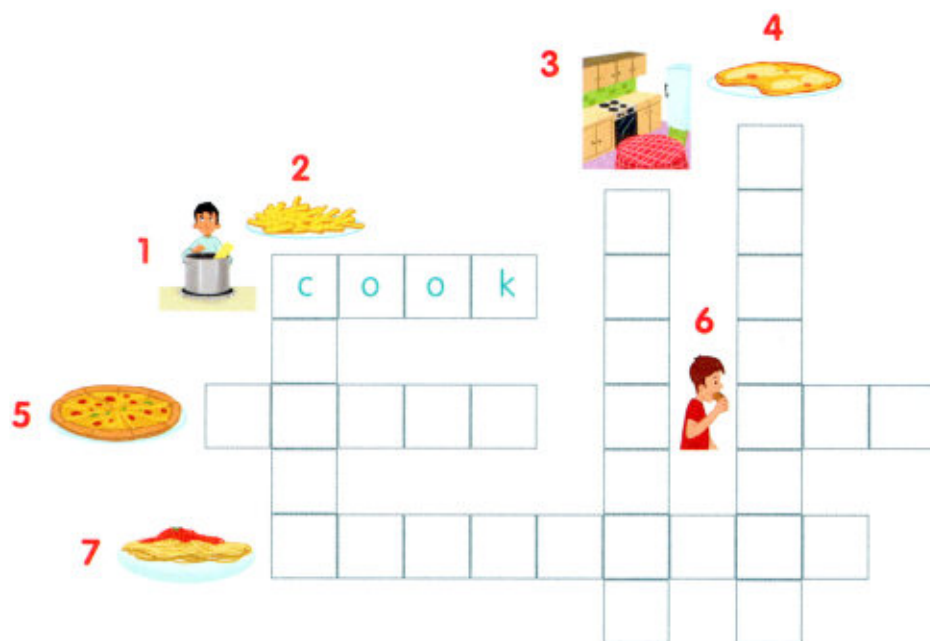

C Write 'm eating or 's eating.

- He 's eating pizza.
- I _____ chips.
- It _____ spaghetti.
- Lily _____ an omelette.
- Matt _____ chips and pizza.

D Write.

He's cooking spaghetti. I'm cooking an omelette.
He's eating spaghetti. She's cooking pizza.
I'm eating pizza. It's eating a fish.

He's cooking spaghetti.













E Write.

He _____ chips and pizza!

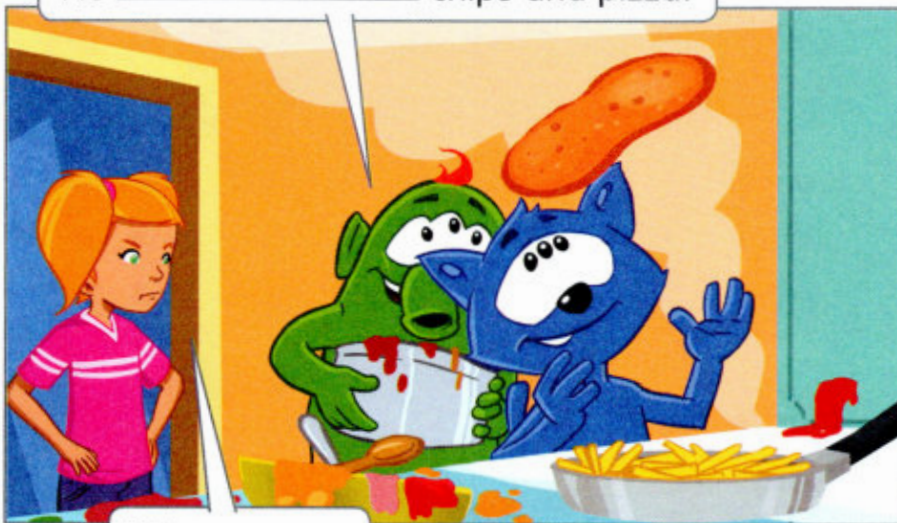

What a mess!

She _____
spaghetti, omelette,
chips and pizza!



Yummy!

A Circle.



run / walk



sing / jump



walk / dance



dance / play the guitar



run / sing



jump / run

B Write.



1 d a n c e



2 _ _ _ g



3 j _ _ _



4 _ _ | _



5 _ _ _ n



6 _ _ _ _ y the gui _ _ _ _

C Write.

- 1 We are dancing . (dance)
- 2 They _____ . (sing)
- 3 You _____ . (run)
- 4 Fizz and Buzz _____ . (jump)
- 5 You _____ . (dance)
- 6 We _____ . (walk)
- 7 They _____ spaghetti. (eat)

D Write.

1 in the field. walking We're



We're walking in the field.

2 jumping They're on the bed.



3 under the table. Two ants are running



4 playing the guitar. You're



5 in the kitchen. are cooking Fizz and Buzz



6 dancing in the house. We're



E Write.

We're singing and _____
with Bip and Bop.

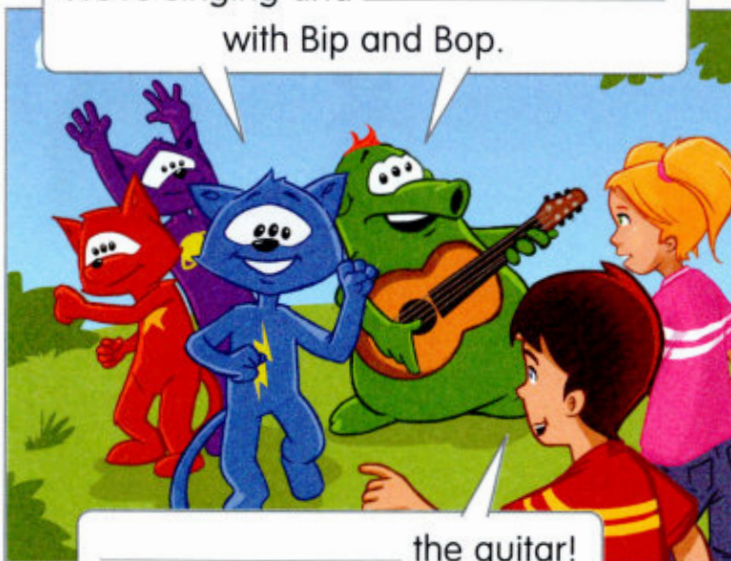

_____ the guitar!

Now _____ ! It's fun!



A Write.

jacket dress T-shirt shoes ~~jeans~~ trousers skirt

1 j e a n s

2 _____



3 _____

4 _____

5 _____



6 _____

7 _____

B Read and write.

- 1 She isn't wearing jeans. She's wearing a dress .
- 2 He isn't wearing a jacket. He's wearing a T-shirt .
- 3 He isn't wearing shoes.
- 4 She's wearing green trousers.



a

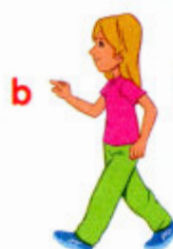

b



c



d



C Write isn't or aren't.

- 1 They aren't running.
- 2 He _____ walking.
- 3 We _____ jumping.
- 4 It _____ eating.
- 5 You _____ cooking.

D Write.

- 1 We aren't eating (eat). We're playing.
- 2 She _____ (wear) a dress. She's wearing jeans.
- 3 They _____ (jump). They're running.
- 4 I _____ (sing). I'm dancing.
- 5 You _____ (run). You're walking.
- 6 He _____ (play) the guitar. He's singing.

E Circle.

Bip and Bop (1) **are** / **aren't** jumping in the field with Fizz. Fizz (2) **is** / **isn't** playing his guitar. Matt and Lily (3) **are** / **aren't** wearing T-shirts. Matt (4) **is** / **isn't** wearing a red T-shirt and Lily (5) **is** / **isn't** wearing a pink T-shirt. They (6) **are** / **aren't** wearing jackets. John (7) **is** / **isn't** wearing grey trousers and a blue T-shirt. Mary (8) **is** / **isn't** wearing a yellow T-shirt and a purple skirt. They (9) **are** / **aren't** running. They (10) **are** / **aren't** walking.



F Read and write.

I'm wearing a red T-shirt and blue jeans. I'm not wearing a jacket. My friend is wearing a grey dress and a black jacket. She isn't wearing jeans.

Are you sleeping?

A Match.

- 1 eat 2 drink 3 sleep 4 have a shower 5 breakfast



B Circle.



They're **eating breakfast** / having a shower.



He's **having a shower** / drinking.



He's **eating** / drinking.



They're **sleeping** / eating breakfast.



We're **sleeping** / eating.

C Write.

- 1 is Tom playing the guitar. No, he isn't.
- 2 _____ Mum drinking? No, she isn't.
- 3 _____ Buzz and Fizz jumping? Yes, they are.
- 4 _____ you happy, Lily? Yes, I am.
- 5 _____ Grandma wearing a dress? Yes, she is.

D Write.

- 1 Are you singing, Matt? Yes, I am _____.
- 2 Are Tom and Betty sleeping? No, _____.
- 3 Is the girl eating breakfast? Yes, _____.
- 4 Is Dad cooking spaghetti? No, _____.
- 5 Is the bird drinking? Yes, _____.
- 6 Are you walking, Matt and Lily? No, _____.

E Write.



What are you doing?

A Match.

1 draw

2 paint

3 write

4 read



B Write.



1 What are you doing?
I'm **painting** / writing.



2 What is he doing?
He's **reading** / drawing.



3 What am I doing?
You're **reading** / writing.

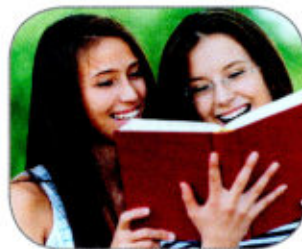

4 What are they doing?
They're **singing** / reading.

C Write.

- 1 What is he doing? He's reading.
- 2 What _____ doing? She's painting.
- 3 What _____ doing? I'm writing.
- 4 What _____ doing? It's drinking.
- 5 What _____ doing? They're drawing.

D Write.



1 What are you doing?

I'm eating.



2 _____

He's drawing.



3 _____

They're jumping.



5 _____

She's reading.

4 _____

I'm dancing.

E Write.

- 1 Are you reading a book? _____
- 2 Are you writing? _____
- 3 Are you wearing jeans? _____
- 4 What are you doing? _____

F Write.

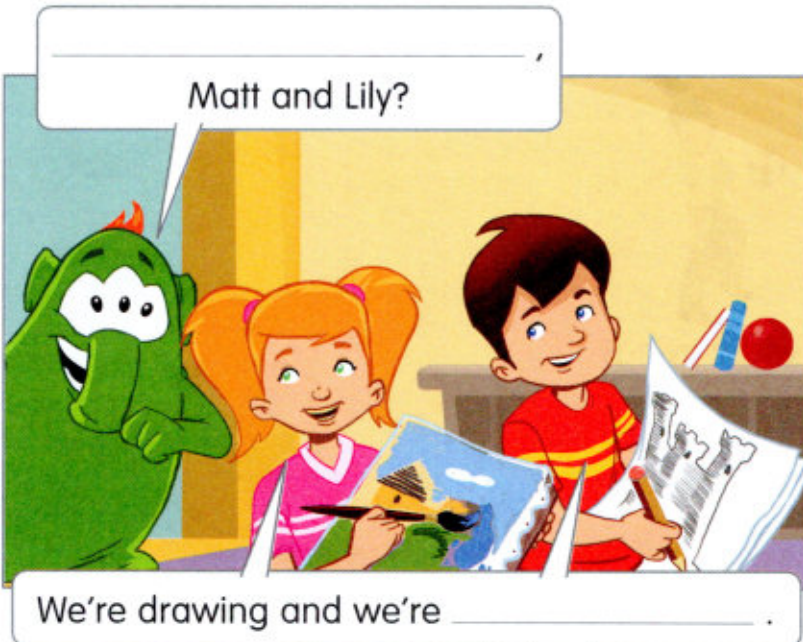

A Circle and write.

1 football

2 _____



3 _____

t	t	u	f	o	o	t	b	a	l	l	b
e	d	b	a	s	k	e	t	b	a	l	l
n	g	b	e	n	n	i	b	h	j	k	l
n	w	a	t	e	r	p	o	l	o	p	q
i	v	v	o	l	l	e	y	b	a	l	l
s	y	z	n	o	p	q	r	s	t	v	w



4 _____



5 _____

B Write.



1 What are they playing?
They're playing basketball.



2 What's she playing?
She's playing _____.



3 What are you playing?
I'm playing _____.



4 What's he playing?
He's playing _____.



5 What are they playing?
They're playing _____.



C Match.

- | | |
|--------------------------|---------------------------------|
| 1 What are you reading? | a She's wearing a blue dress. |
| 2 What's he eating? | b You're drawing a tree. |
| 3 What's she wearing? | c I'm reading a book. |
| 4 What are they playing? | d He's eating your pizza. |
| 5 What am I drawing? | e It's running under the table. |
| 6 What's it doing? | f They're playing volleyball. |

D Write.

sing paint wear ~~eat~~ cook drink



- 1 What are you eating _____ ?
- 2 What _____ ?
- 3 What _____ ?
- 4 What _____ ?
- 5 What _____ ?
- 6 What _____ ?



E Write.

- | | |
|--|--|
| 1 What <u>are you playing</u> _____ ?
I'm playing the guitar. | 4 What _____ ?
He's reading a book. |
| 2 What _____ ?
They're painting the house. | 5 What _____ ?
It's eating a fish. |
| 3 What _____ ?
She's wearing a blue jacket. | |

A Circle and match.

h o p s w i m c l i m b d i v e f l y



B Write.



1 I can s w i m .



2 She can _____ .



3 She can _____ .



4 It can _____ .

5 He can _____ .

C Write can or can't.

1 Can you hop?
No, I can't .

2 _____ she climb?
Yes, _____ .

3 _____ it swim?
No, _____ .

4 _____ they dance?
Yes, _____ .

5 _____ Matt dive?
Yes, _____ .

6 _____ Tom and Betty fly?
No, _____ .



D Read and write.

I can play basketball but
I can't play volleyball.
I can swim, too.
I can't dive.

Page 87

E Write.



A Write.

close ~~open~~ touch door sit down stand up

1 open _____



2 _____



3 _____



4 _____



5 _____



6 _____

B Read and number.

- 1 Open your books!
- 2 Close your eyes!
- 3 Sit down!
- 4 Close the door!

a



b



c



d



C Write.

- 1 Sit on the sofa! Don't sit on the table!
- 2 Sing in your bedroom! _____ in the kitchen!
- 3 Run in the fields! _____ in the house!
- 4 Climb the tree! _____ on the car!
- 5 Eat in the kitchen! _____ in your bedroom!
- 6 Play basketball! _____ tennis!

D Write.

play touch sit read swim sleep



X

1 Don't swim in the sea!



✓

2 _____ your guitar, please!



X

3 _____ on my pizza!



X

4 _____ the cat!



✓

5 _____ your book, please!



X

6 _____ in the classroom!

E Write.

Don't _____, Fizz!
_____ up!



_____ late!



Oh, no!

A Match.

- 1 pirate 2 in front of 3 behind 4 treasure 5 dig 6 map



B Write.



C Write.

in front of behind in on under

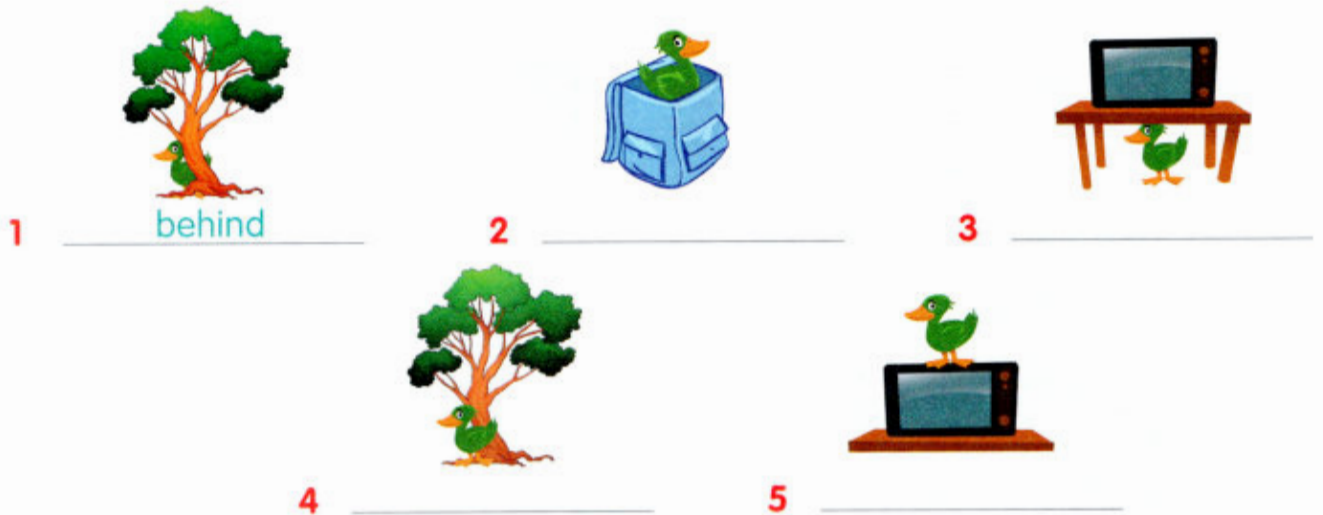

D Write.

sing jump write play dance run



1 Let's play water polo!



2 _____ in our books!



3 _____ !



4 _____ !



5 _____ !



6 _____ !

E Write.

Just _____ minute!
I've got a good _____ !
_____ fly there!





Review 3

Units 7-9

A Write.

cook drink sing dance jump walk run
climb fly swim dive read write draw paint



_____ cook _____



B Read and circle.



Jack's wearing a purple (1) T-shirt / jacket and grey (2) shoes / trousers. He's wearing black (3) jeans / shoes. Jenny's wearing a white (4) dress / T-shirt, a blue (5) jacket / dress and brown (6) jeans / shoes.

C Write and match.

- 1 He's playing the g u i t a r .
- 2 He's playing b _____ .
- 3 He's playing w _____ .
- 4 He's eating c _____ .
- 5 He's opening the d _____ .

c



D Match.

- | | |
|------------------------------|---------------------------------------|
| 1 What are they playing? | a No, he isn't. He's painting a tree. |
| 2 Are you dancing? | b He's hopping on one leg. |
| 3 What's he doing? | c They're playing football. |
| 4 Is he painting the sea? | d Yes, I am. |
| 5 What's she wearing? | e No, they aren't. |
| 6 Are they eating spaghetti? | f She's wearing a T-shirt and jeans. |

E Write.

- | | |
|---|---|
| 1 <u>Are you</u> touching your head?
No, I <u>'m not</u> . | 4 She's digging in the field.
_____ digging on the hill. |
| 2 _____ having a shower?
No, he _____. | 5 We aren't eating pizza.
_____ eating an omelette. |
| 3 _____ sleeping?
Yes, they _____. | 6 You're closing the door.
_____ opening the door. |

F Write.

- | |
|--|
| 1 <u>Can</u> that boy sing? Yes, <u>he can</u> . |
| 2 _____ that pirate dance? No, _____. |
| 3 _____ ants write? No, _____. |
| 4 _____ Betty play tennis? Yes, _____. |
| 5 _____ that cat swim? No, _____. |
| 6 _____ kangaroos jump? Yes, _____. |

G Write.

in on behind in front of under

Lily is reading her book (1) under the table.
Fizz is jumping (2) _____ the sofa. Matt is
playing the guitar (3) _____ the sofa. Buzz
is eating pizza (4) _____ the sofa. Lulu, the
baby, is playing (5) _____ the cupboard!



Have you got any apples?*

A Write.

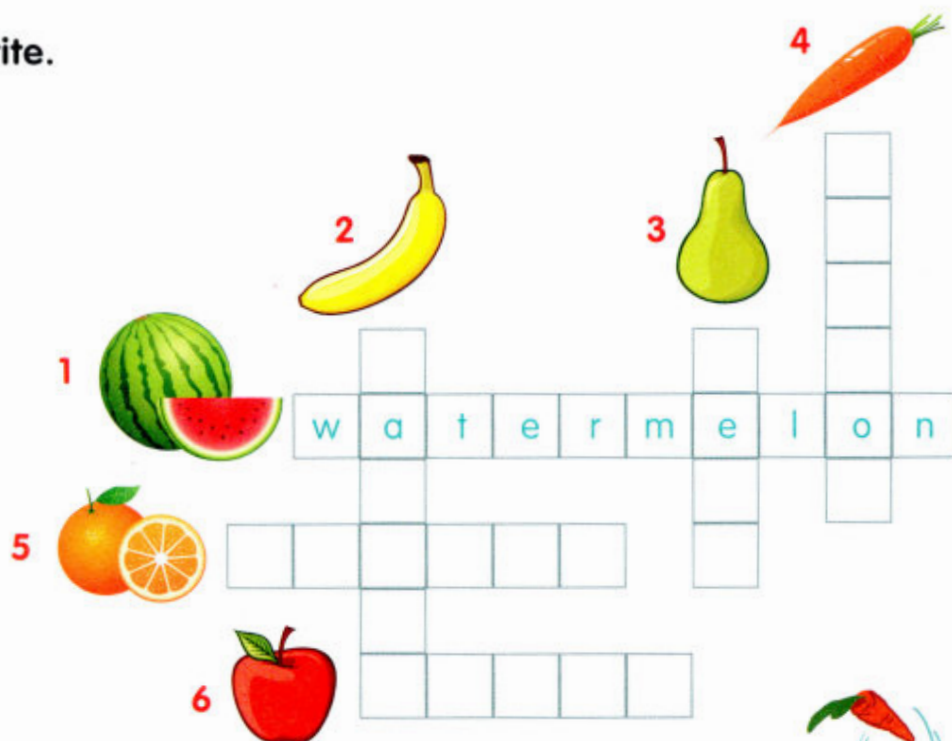

B Write.

Fizz has got some (1) c arrots and some (2) p _____. He hasn't got any (3) a _____.

Buzz has got some (4) b _____ and some (5) o _____. He hasn't got any (6) w _____.



C Write some or any.

- 1 I've got some apples in my shop. I haven't got any pears.
- 2 He's got _____ rulers in his school bag. He hasn't got _____ books.
- 3 We've got _____ pencils on our desks. We haven't got _____ pens.
- 4 She hasn't got _____ blankets on her bed.
- 5 They've got _____ jackets in the cupboard.
- 6 You haven't got _____ cousins.

D Write **some** or **any**.

- 1 Have you got any bananas?
Yes, I've got some bananas.
- 2 Has he got _____ flowers?
No, he hasn't got _____ flowers.
- 3 Have they got _____ maps in the car?
No, they haven't got _____ maps.
- 4 Has she got _____ pears?
Yes, she's got _____ pears.
- 5 Have you got _____ toys?
Yes, I've got _____ toys.

E Write.



Yes, Fizz. I've got _____ apples and _____ bananas, too.

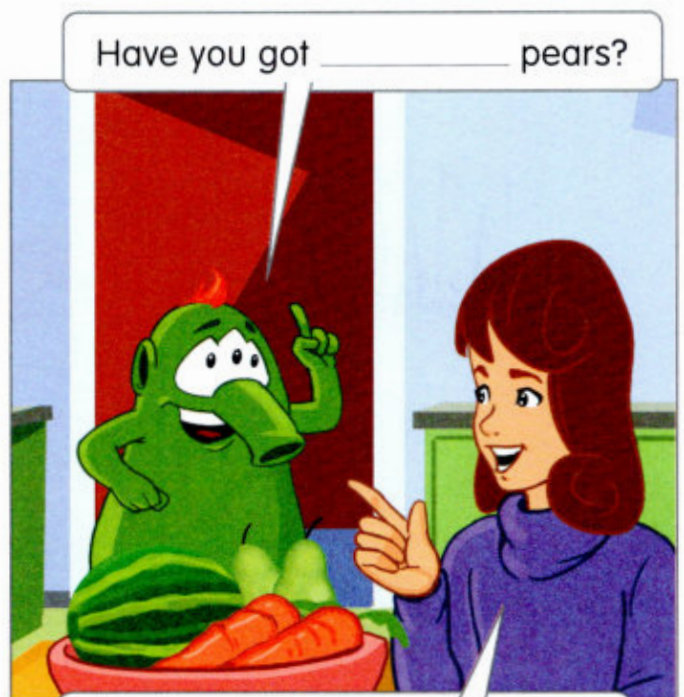

Yes! I've got _____ pears. I've got _____ carrots and a _____, too.

A Match.

1 tomato

2 potato

3 peach

4 cherry



5 box

6 glass

7 dish

8 juice

B Count and write.



1 two peaches



2 _____



3 _____



4 _____



5 _____



6 _____

C Write.

- 1 There are some peaches on the table.
- 2 _____ glasses on the table.
- 3 _____ tomatoes on the table.
- 4 _____ cherries on the table.
- 5 _____ potatoes on the table.



D Write **some** or **any**.

- 1 Are there any teddies in your bedroom?
Yes, there are _____ teddies.
- 2 Are there _____ babies in your family?
No, there aren't _____ babies in our family.
- 3 Are there _____ carrots in the kitchen?
No, there aren't _____ carrots.
- 4 Are there _____ boxes in the cupboard?
Yes, there are _____ boxes.
- 5 Are there _____ potatoes in the box?
No, there aren't _____ potatoes.

E Read and write.

There are some toys in my bedroom.
There are some small cars and two balls.
There aren't any teddies. There aren't
any books. There are some T-shirts and
some trousers in my cupboard.

Page 87

F Write.



There are some _____
on this tree!

There are _____
cherries on that tree!

Let's stand on these _____.

A Write.

mouse foot tooth ~~man~~ woman child



1 man



2 _____



3 _____



4 _____



5 _____



6 _____

B Write.

1 mouse mice

4 child _____

2 foot _____

5 man _____

3 tooth _____

6 woman _____

C Write.

1 Where are the mice?

5 _____ the mouse?

2 _____ the children?

6 _____ the child?

3 _____ the man?

7 _____ the men?

4 _____ the woman?

8 _____ the women?



D Write.

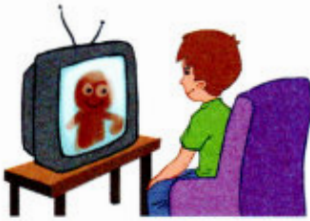

1 Where is the child?

The child is in front of the TV.

2

The man is behind the car.



3

The women are on the boxes.



4

The mouse is under the bed.

5

The teeth are in the glass.

E Write.

Look! There's a mouse!
There's a mouse in the house.
Look! There are two
Two _____ in my shoe.

Where _____ the cat?
The cat is on the bed.
_____ the mice?
The mice are _____ its head.



A Write.



- | | | |
|---|----------------------|---------------|
| 1 | _____ <u>Mon</u> day | <u>Monday</u> |
| 2 | _____ day | _____ |
| 3 | _____ day | _____ |
| 4 | _____ day | _____ |
| 5 | _____ day | _____ |
| 6 | _____ day | _____ |
| 7 | _____ day | _____ |

B Match.

- Every Saturday, we play tennis.
- They cook spaghetti on Tuesdays.
- On Wednesdays, I swim.
- Every Friday, you read your books.
- On Mondays, I paint.
- You sing every Sunday.
- On Thursdays, the children write.



C Write.

play swim sleep draw wear

- Every Monday, I swim in the sea.
- On Fridays, we _____ water polo.
- Every Tuesday, you _____ birds.
- They _____ their jeans on Wednesdays.
- At the weekend, I _____ in my bed.

D Write.

- 1 tennis / play / they / Wednesdays / on
On Wednesdays, they play tennis.
- 2 the fields / walk / on / Tuesdays / in / you / the
On _____
- 3 Friday / every / climb / we / trees
Every _____
- 4 Saturdays / on / they / spaghetti / cook
They _____
- 5 jump / sea / in / the / every / we / Sunday
We _____

E Read and write.

On Saturdays, I play
football. On Sundays, I draw
and I read my book.

F Write.



At the weekend, I _____ !
I like Saturdays and _____ !

A Match.

1 get up

2 go to bed

3 like

4 brush

5 watch

a



b



c



d



e



B Write.

On Mondays, Jenny (1) **gets up** / **goes to bed**. She (2) **brushes** / **watches** her hair and she eats her breakfast. She (3) **brushes** / **likes** her teeth and she (4) **goes** / **watches** to school. She plays with her friends, Betty and Penny. She (5) **cooks** / **likes** her friends!



C Circle.

- 1 He **watch** / **watches** TV with his dad on Sundays.
- 2 The cat **sleeps** / **sleep** on its blanket.
- 3 Her mum **cook** / **cooks** spaghetti on Tuesdays.
- 4 Every weekend, he **play** / **plays** football.
- 5 She **like** / **likes** pizza.



D Write.

- 1 We play tennis at the weekend.
She _____ **plays** _____ tennis every Wednesday.
- 2 You like potatoes.
Tom _____ tomatoes.
- 3 I watch TV on Saturdays.
Bill _____ TV on Sundays.
- 4 They go to school with their mum.
Mary _____ to school with her dad.
- 5 We walk to our grandma's house at the weekend.
Our dog _____ to her house, too.

E Write.

go brushes goes watches
like brush watch likes

- 1 He _____ **goes** _____ to school every day.
- 2 I _____ to school with my friends.
- 3 We _____ TV with Mum and Dad.
- 4 She _____ TV with Tom.
- 5 Matt _____ spaghetti.
- 6 I _____ chips.
- 7 They _____ their teeth every day.
- 8 She _____ her hair every day.

F Read and write.

My friend Mike likes Saturdays. He plays basketball with his friends. He likes basketball. He eats pizza and he watches TV with his mum and dad.

A Circle.

1 water / milk

2 crisps / sweets



3 lemonade / juice



4 sweets / water



5 milk / crisps

B Match and write.

- Tom doesn't like water.
- Lily doesn't drink _____.
- Matt and Betty don't like _____.
- Cows don't drink _____.
- Lulu doesn't eat _____.

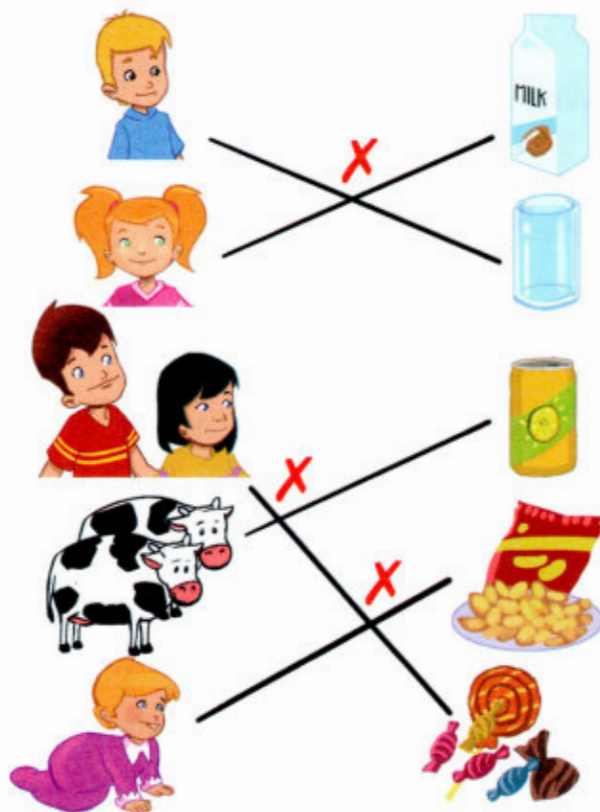

C Write don't or doesn't.

- We don't eat carrots.
- She _____ play tennis.
- It _____ like milk.
- They _____ wear jeans.
- I _____ climb trees.
- He _____ swim every day.



D Write.

- 1 Emma eats apples. She doesn't eat pears.
- 2 Dad watches TV on Sundays. He _____ TV on Saturdays.
- 3 I like sweets. I _____ milk.
- 4 They play volleyball. They _____ football.
- 5 Matt's cat drinks water. It _____ lemonade.
- 6 We sleep in our bedroom. We _____ in the kitchen.

E Write.

Mike	sweets	X
Penny	pizza	✓
Ken and John	milk	X
Matt's cat	water	✓
Fizz and Buzz	crisps	✓
Emma	oranges	X

- 1 Mike doesn't like sweets.
- 2 Penny _____.
- 3 Ken and John _____.
- 4 Matt's cat _____.
- 5 Fizz and Buzz _____.
- 6 Emma _____.



F Read and write.

I like pizza, sweets and milk.
I don't like water.
My friend Penny likes pizza, too.
She doesn't like milk.

A Write.

spring summer autumn ~~winter~~

- 1 We wear our jackets in winter.
- 2 We swim in the sea in _____.
- 3 There are flowers in _____.
- 4 The trees are brown and orange in _____.

B Write.

1  →

2  →

3  →

4  →

C Match.

- | | | |
|--------------------------|---|-------------------|
| 1 Do you swim in summer? |  | a Yes, they do. |
| 2 Do birds fly? | | b Yes, I do. |
| 3 Do cows dance? | | c No, we don't. |
| 4 Do you like winter? | | d No, they don't. |



D Write.

- 1 Do they like summer?
Yes, they do.
- 2 _____ you eat sweets every day,
Tom and Betty?
No, _____.
- 3 _____ snakes fly?
No, _____.
- 4 _____ you play basketball, Bob?
Yes, _____.
- 5 _____ Lily and Matt climb trees?
Yes, _____.

E Write about you.

- 1 Do you like sweets?
Yes, I do. / No, I don't.
- 2 Do you like football?

- 3 Do you like snakes?

- 4 Do you like winter?

- 5 Do you like spaghetti?

F Write.

_____ you swim in the sea
in summer, Matt and Lily?

Yes, _____. We swim in the
sea every day in _____.

_____ you like winter,
Fizz and Buzz?

No, we _____!

A Circle.



snight abceveningfghafternoonklnmorningp

B Write.



- 1 Do you play tennis in the afternoon ?



- 2 Do you eat breakfast in the _____ ?



- 3 Does your dad watch TV in the _____ ?



- 4 Does your cat sleep at _____ ?

C Write.

- 1 Betty drinks juice in the morning.
Does she drink _____ juice in the evening?
- 2 Your brother plays basketball.
 _____ volleyball?
- 3 Lily reads at night.
 _____ in the afternoon?
- 4 Matt's cat drinks milk.
 _____ water?
- 5 Tom wears his jacket in winter.
 _____ his jacket in autumn?

D Write.



- 1 Does Fizz like winter?
No, he doesn't.



- 2 Does Bob brush his teeth in the evening?



- 3 Does Lily dive in the sea in summer?



- 4 Does the cat wear shoes?



- 5 Does the pirate wear jeans?

E Write **do**, **does**, **don't** or **doesn't**.

- 1 Does Fizz play the guitar?
Yes, he does.
- 2 _____ you like flowers?
Yes, I _____.
- 3 _____ they eat carrots?
No, they _____.
- 4 _____ she play tennis?
No, she _____.
- 5 _____ Dad paint the house?
Yes, he _____.

F Write.

_____ Buzz have a shower every day?

No, he _____.
He has a shower every Monday!

What a _____!

A Match.

- 1 do the housework 2 wash the dishes 3 floor 4 window 5 o' clock

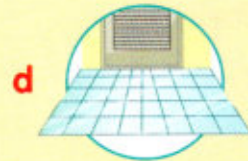

B Write.



- 1 John does the housework every Wednesday.
 2 They _____ the car every Sunday.
 3 She washes the _____ every day.
 4 I wash the _____ on Mondays.
 5 We eat breakfast at eight _____ every day.

C Circle.

- 1 What **do** / **does** he do in winter?
 2 What **do** / **does** you do in the morning?
 3 What **do** / **does** Lily do in summer?
 4 What **do** / **does** they do in the evening?
 5 What **do** / **does** it do at night?

D Write **do** or **does**.

- 1 What does Matt do in autumn?
He climbs trees.
- 2 What _____ they _____ every Monday?
They go to school.
- 3 What _____ the cat _____ every day?
It sleeps.
- 4 What _____ Tom and Matt _____ at the weekend?
They play football.
- 5 What _____ Lily _____ in summer?
She swims in the sea.
- 6 What _____ you _____ on Wednesdays?
I do the housework.

E Write.





Review 4

Units 10-12

A Write.



B Match.



in the afternoon
at night
in the morning
in the evening



C Write.



- 1 m i c e
2 _ e _
3 _ o _ e _
4 _ e _ _ _
5 _ h _ _ _ r _ n
6 _ _ e _

D Circle.

- 1 There are **some** / **any** sweets on the table.
2 There are **some** / **any** tomatoes in the box.
3 Are there **some** / **any** apples on the tree?
4 There aren't **some** / **any** flowers in winter.
5 Has he got **some** / **any** pens?
6 She's got **some** / **any** peaches in the kitchen.

E Write is or are.

- 1 Where is my shoe?
2 Where _____ your cousin?
3 Where _____ the boxes?
4 Where _____ the men?
5 Where _____ my apple?
6 Where _____ the children?

F Write.

	✓	✗
1 like	pears	peaches
2 drink	water	milk
3 swim	morning	night
4 play	volleyball	football
5 brush	teeth	hair

- I like pears. I don't like peaches.
- The cat _____ water. It _____ milk.
- We _____ in the morning. We _____ at night.
- Penny _____ volleyball. She _____ football.
- They _____ their teeth every day. They _____ their hair.

G Write.

Every morning at eight o'clock, Matt (1) gets up and he has a shower. He eats his breakfast and he (2) _____ his teeth. He (3) _____ to Tom's house and he plays with his cousins. He walks to his house in the afternoon. In the evening, he (4) _____ TV with his mum and dad. At nine o'clock, Matt (5) _____.



H Write do, does, don't or doesn't.

- Does he cook every day? No, he doesn't.
- _____ Lily like cherries? Yes, she _____.
- _____ birds sleep at night? Yes, they _____.
- _____ you like mice? No, I _____.
- _____ Matt eat tomatoes every day? No, he _____.



Unit 2 Lesson 3 (page 15)

F Read, draw and write.

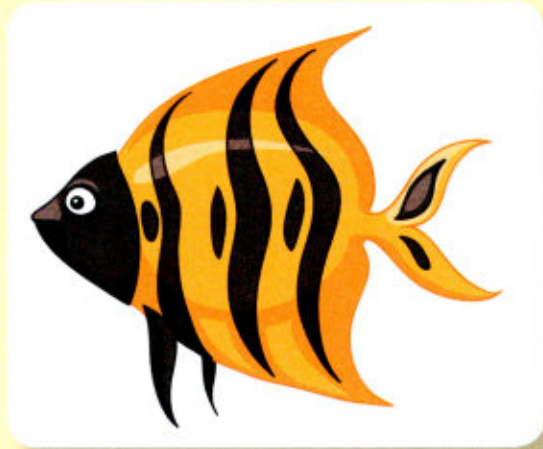

This is a fish.
It's orange and black.



Unit 3 Lesson 2 (page 19)

F Read and write.

Hello, I'm Alex.
I'm eight.
How old are you?

Unit 4 Lesson 2 (page 27)

G Read and write.

My school bag is blue.
There are two books and
a ruler in my school bag.
There is a red pencil and
a black pen.

Unit 5 Lesson 1 (page 31)

F Read, draw and write.



Hello, I'm Fred.
This is my family. I've got a mum
and a brother. I've got a grandpa
and two grandmas. I've got an
aunt, an uncle and a cousin.

A large, empty rounded rectangle with a light blue border, intended for drawing a picture related to the family description.



Unit 5 Lesson 3 (page 35)

G Read and write.

Hello, I'm Penny. I've got blonde hair and blue eyes. My mum's got blonde hair and my dad's got brown hair. My brother's got blonde hair and brown eyes.

Unit 7 Lesson 3 (page 49)

F Read and write.

I'm wearing a red T-shirt and blue jeans. I'm not wearing a jacket. My friend is wearing a grey dress and a black jacket. She isn't wearing jeans.



Unit 9 Lesson 1 (page 57)

D Read and write.

I can play basketball
but I can't play
volleyball.
I can swim, too.
I can't dive.

Unit 10 Lesson 2 (page 67)

E Read and write.

There are some toys in
my bedroom. There are
some small cars and
two balls. There aren't
any teddies. There
aren't any books. There
are some T-shirts and
some trousers in my
cupboard.



Unit II Lesson 1 (page 71)

E Read and write.

On Saturdays, I play
football. On Sundays,
I draw and I read
my book.

Unit II Lesson 2 (page 73)

F Read and write.

My friend Mike likes
Saturdays. He plays
basketball with his
friends. He likes
basketball. He eats
pizza and he
watches TV with his
mum and dad.

Fun with Fizz

Ann Jones
Activity Book

Fun with Fizz is an entertaining new primary course for young learners. The exciting adventures of the mischievous alien Fizz will engage your pupils' attention and make learning English fun.

Fun with Fizz provides pupils with a carefully-graded syllabus which gradually develops their vocabulary and language skills through fun stories, clear and user-friendly lesson organisation and ample practice and revision.

Fun with Fizz Activity Book 1 is in full colour and has been designed to practise and consolidate the lexical and grammatical items presented in *Fun with Fizz Pupil's Book 1*. It contains a wide variety of stimulating tasks which reinforce what pupils have learnt in class and further develop their reading and writing skills.

Fun with Fizz Activity Book 1 contains:

- fun activities that focus on the new language, including crosswords, word searches and picture-based tasks.
- page-for-page practice for every Pupil's Book lesson.
- extra reading and writing tasks in which pupils can write about themselves using the vocabulary and grammar they have just learnt.
- a review after every three units.

Fun with Fizz for the pupil:

- Pupil's Book with stickers
Pupil's Book also includes a free Alphabet and Starter Book, a free Picture Dictionary and a downloadable e-book.
- Activity Book in full colour
- Test book

Fun with Fizz for the teacher:

- Teacher's Book with embedded Pupil's Book and Photocopiable Tests
- Class Audio set
- Alphabet and Starter Book with Key
- Flashcard Pack
- Interactive Whiteboard Software